

ROLLSHUTTER RETROFIT SYSTEM

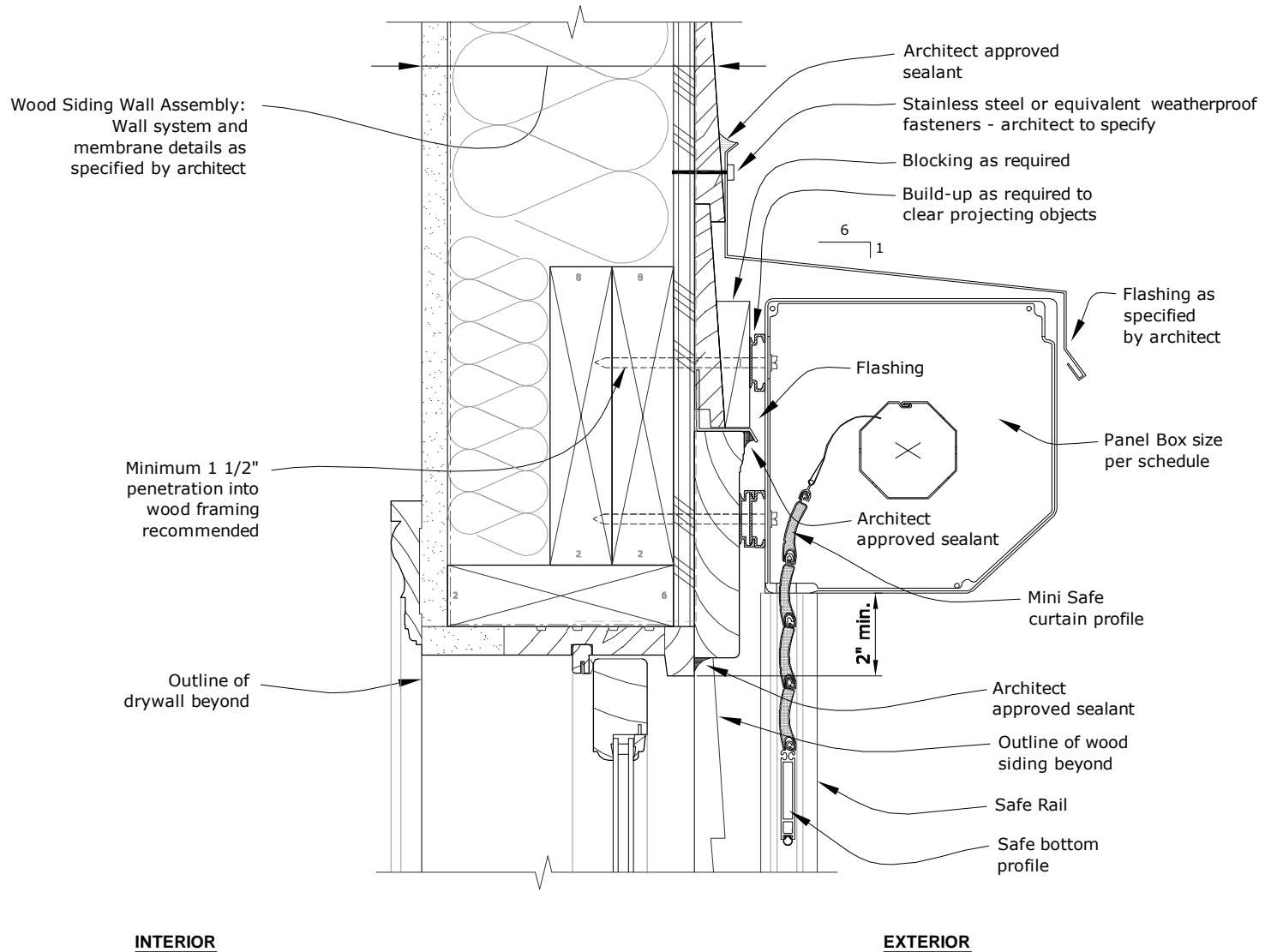

INTERIOR

EXTERIOR

PANEL BOX / WINDOW HEAD DETAIL

NOTE: IT IS THE SOLE RESPONSIBILITY OF THE GENERAL CONTRACTOR TO SUPPLY ALL REQUIRED SEALANTS, FLASHINGS, AND MOUNTING HARDWARE.

DISCLAIMER: DETAILS PROVIDED BY TALIUS ARE GENERAL RECOMMENDATIONS. CONSULTATION WITH AN EXPERIENCED ARCHITECT, STRUCTURAL ENGINEER, OR CONTRACTOR IS NECESSARY FOR PROPER EXECUTION OF WEATHERPROOFING DETAILS, STRUCTURAL REQUIREMENTS AND COMPLIANCE WITH REGIONAL AND LOCAL BUILDING CODES. TALIUS PLACES SOLE RESPONSIBILITY OF THESE INSTALLATION ISSUES WITH THE ARCHITECT, STRUCTURAL ENGINEER, GENERAL CONTRACTOR AND/OR BUILDING OWNER.

ROLLSHUTTER RETROFIT SYSTEM

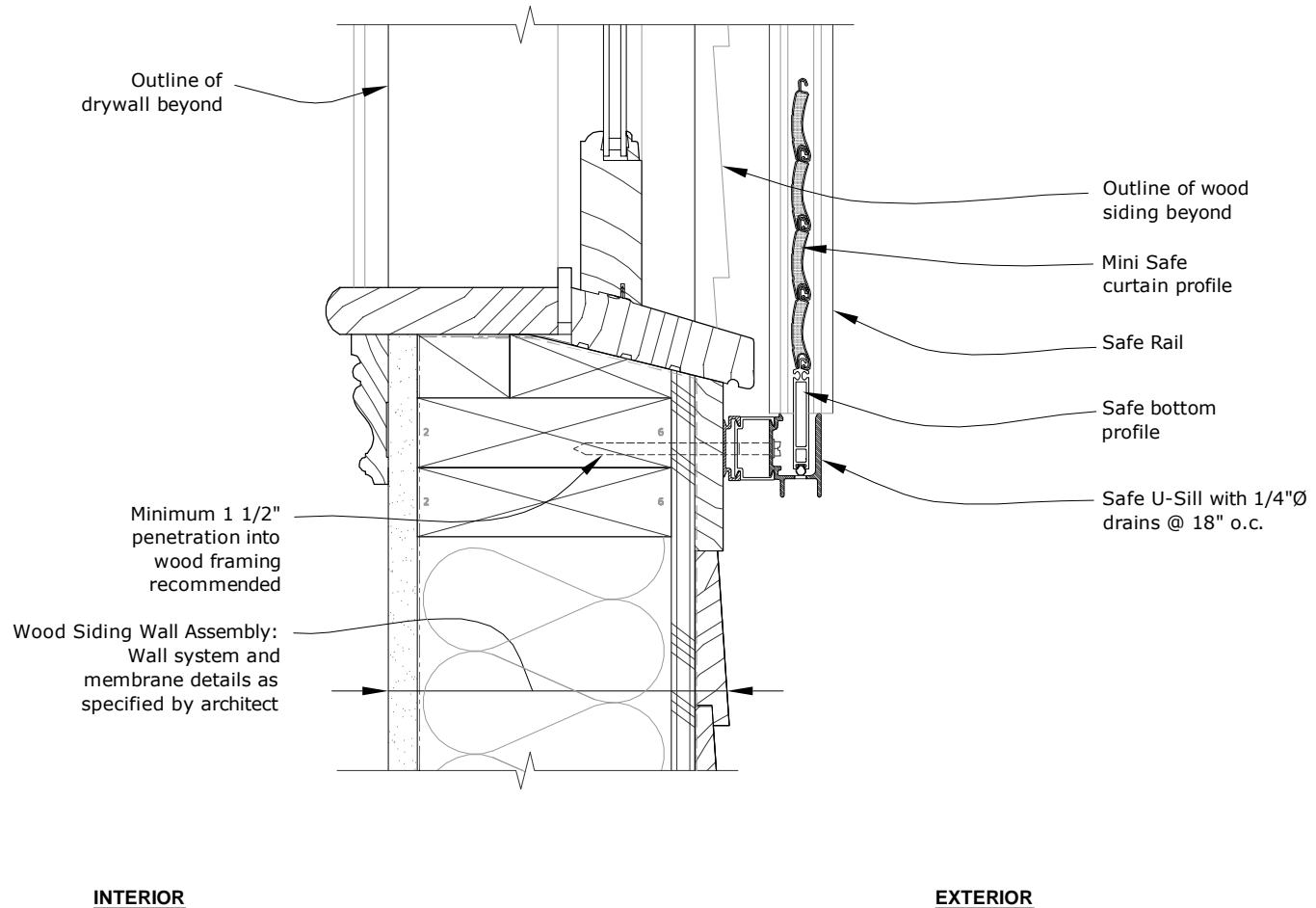

WINDOW SILL DETAIL

NOTE: IT IS THE SOLE RESPONSIBILITY OF THE GENERAL CONTRACTOR TO SUPPLY ALL REQUIRED SEALANTS, FLASHINGS, AND MOUNTING HARDWARE.

DISCLAIMER: DETAILS PROVIDED BY TALIUS ARE GENERAL RECOMMENDATIONS. CONSULTATION WITH AN EXPERIENCED ARCHITECT, STRUCTURAL ENGINEER, OR CONTRACTOR IS NECESSARY FOR PROPER EXECUTION OF WEATHERPROOFING DETAILS, STRUCTURAL REQUIREMENTS AND COMPLIANCE WITH REGIONAL AND LOCAL BUILDING CODES. TALIUS PLACES SOLE RESPONSIBILITY OF THESE INSTALLATION ISSUES WITH THE ARCHITECT, STRUCTURAL ENGINEER, GENERAL CONTRACTOR AND/OR BUILDING OWNER.

ROLLSHUTTER RETROFIT SYSTEM

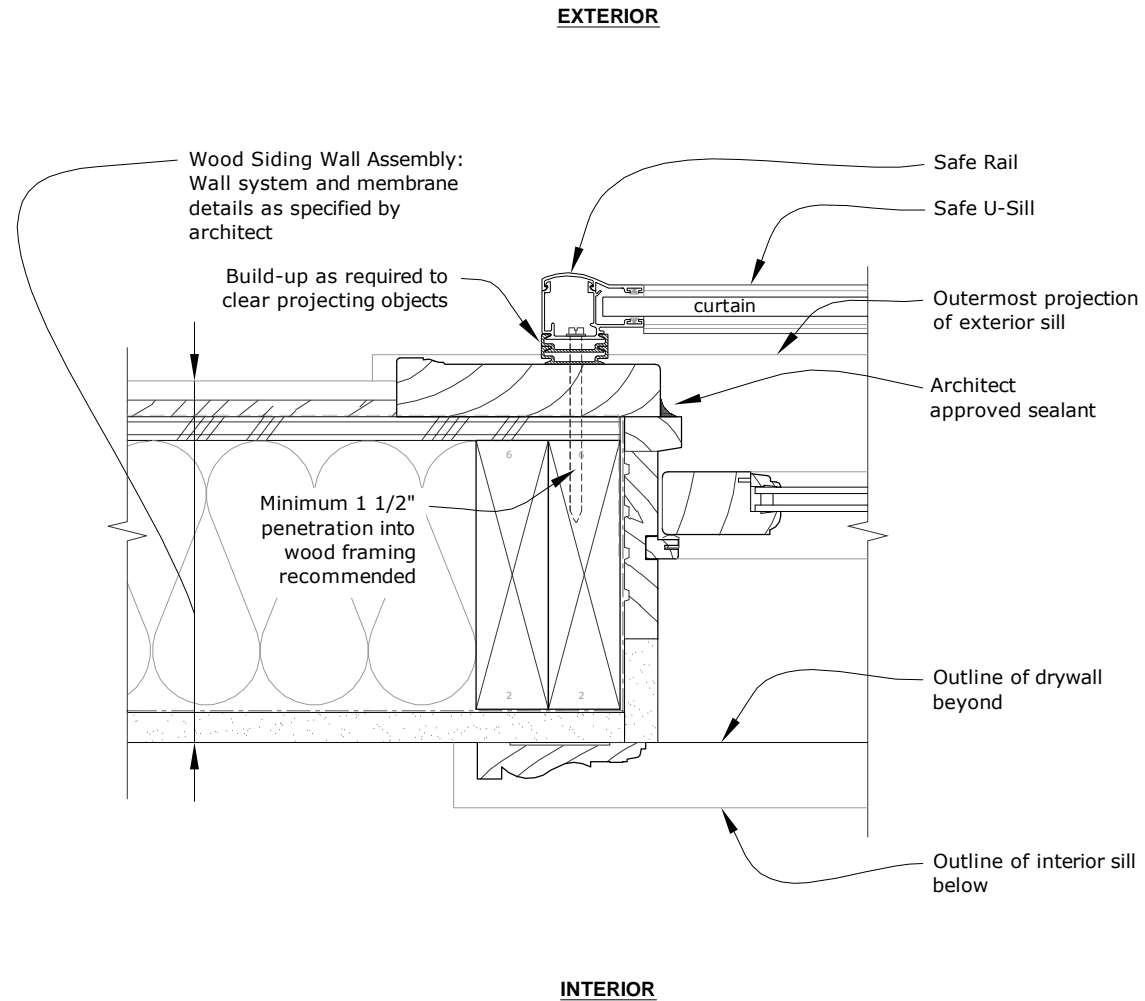

WINDOW JAMB DETAIL

NOTE: IT IS THE SOLE RESPONSIBILITY OF THE GENERAL CONTRACTOR TO SUPPLY ALL REQUIRED SEALANTS, FLASHINGS, AND MOUNTING HARDWARE.

DISCLAIMER: DETAILS PROVIDED BY TALIOUS ARE GENERAL RECOMMENDATIONS. CONSULTATION WITH AN EXPERIENCED ARCHITECT, STRUCTURAL ENGINEER, OR CONTRACTOR IS NECESSARY FOR PROPER EXECUTION OF WEATHERPROOFING DETAILS, STRUCTURAL REQUIREMENTS AND COMPLIANCE WITH REGIONAL AND LOCAL BUILDING CODES. TALIOUS PLACES SOLE RESPONSIBILITY OF THESE INSTALLATION ISSUES WITH THE ARCHITECT, STRUCTURAL ENGINEER, GENERAL CONTRACTOR AND/OR BUILDING OWNER.

ROLLSHUTTER RETROFIT SYSTEM

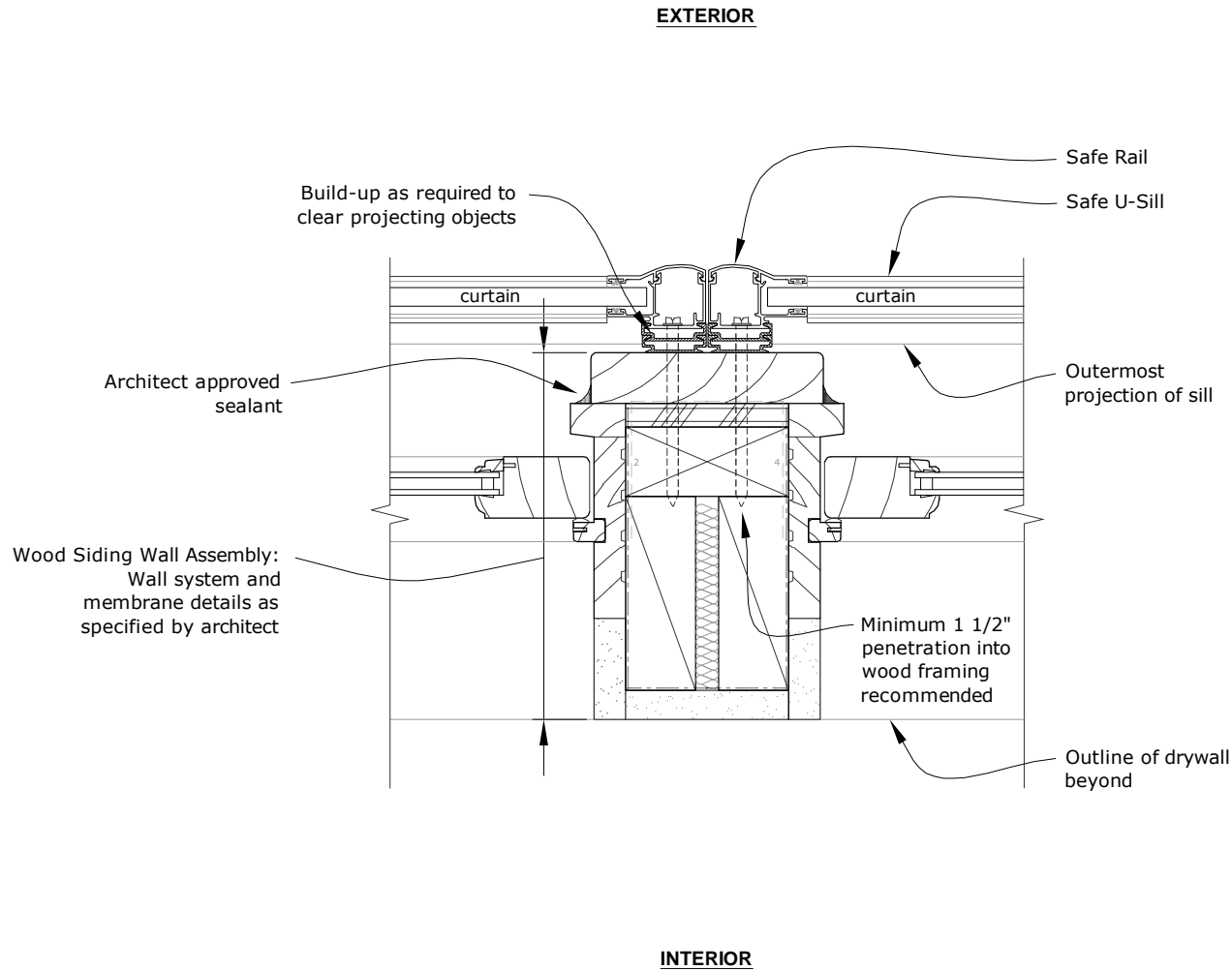

WINDOW JAMB DETAIL w/ SAFE RAILS BACK-TO-BACK

NOTE: IT IS THE SOLE RESPONSIBILITY OF THE GENERAL CONTRACTOR TO SUPPLY ALL REQUIRED SEALANTS, FLASHINGS, AND MOUNTING HARDWARE.

DISCLAIMER: DETAILS PROVIDED BY TALIU S ARE GENERAL RECOMMENDATIONS. CONSULTATION WITH AN EXPERIENCED ARCHITECT, STRUCTURAL ENGINEER, OR CONTRACTOR IS NECESSARY FOR PROPER EXECUTION OF WEATHERPROOFING DETAILS, STRUCTURAL REQUIREMENTS AND COMPLIANCE WITH REGIONAL AND LOCAL BUILDING CODES. TALIU S PLACES SOLE RESPONSIBILITY OF THESE INSTALLATION ISSUES WITH THE ARCHITECT, STRUCTURAL ENGINEER, GENERAL CONTRACTOR AND/OR BUILDING OWNER.

PANEL BOX IN-SOFFIT SYSTEM

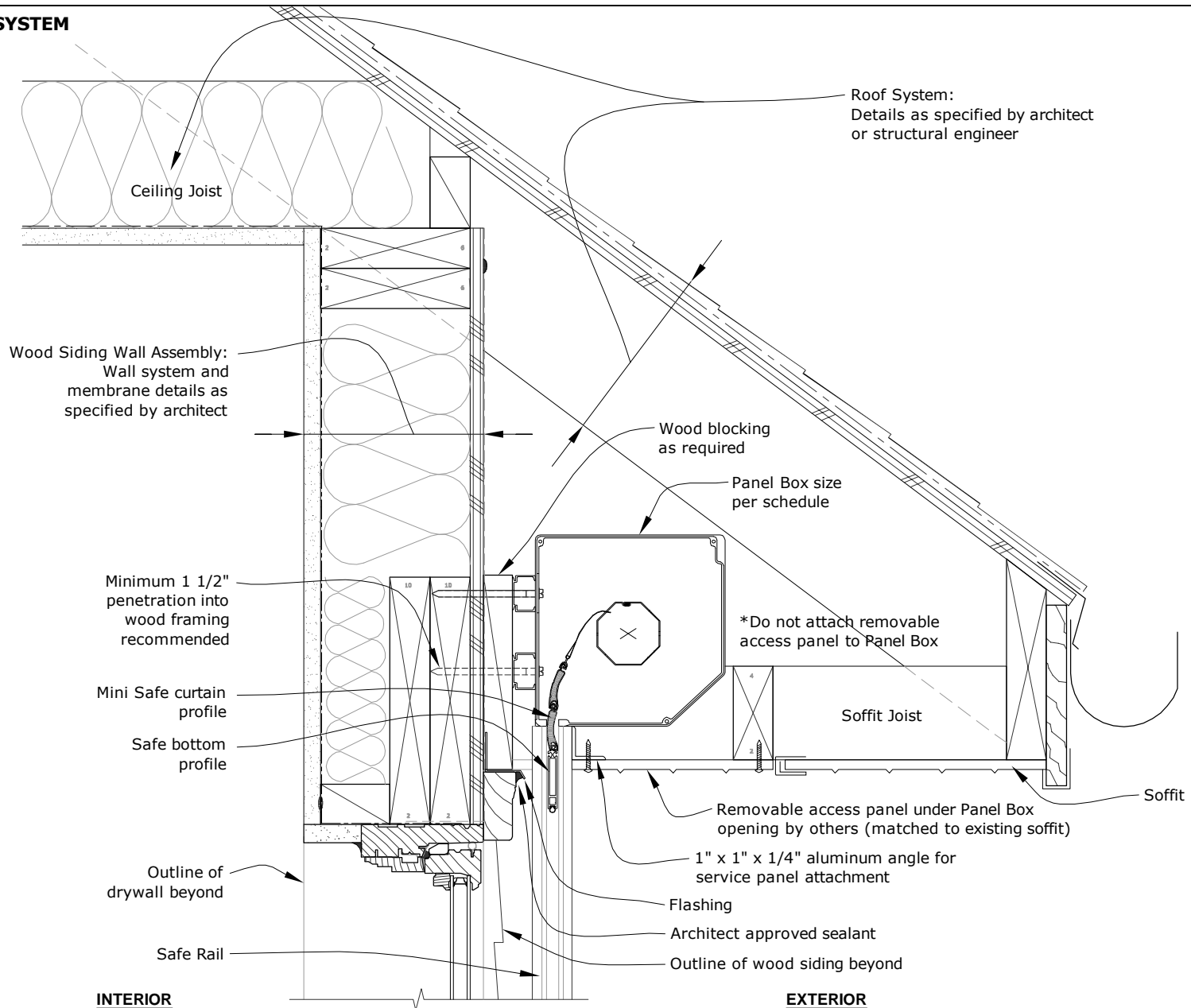

SOFFIT DETAIL

INTERIOR

EXTERIOR

NOTE: IT IS THE SOLE RESPONSIBILITY OF THE GENERAL CONTRACTOR TO SUPPLY ALL REQUIRED SEALANTS, FLASHINGS, AND MOUNTING HARDWARE.

DISCLAIMER: DETAILS PROVIDED BY TALIUS ARE GENERAL RECOMMENDATIONS. CONSULTATION WITH AN EXPERIENCED ARCHITECT, STRUCTURAL ENGINEER, OR CONTRACTOR IS NECESSARY FOR PROPER EXECUTION OF WEATHERPROOFING DETAILS, STRUCTURAL REQUIREMENTS AND COMPLIANCE WITH REGIONAL AND LOCAL BUILDING CODES. TALIUS PLACES SOLE RESPONSIBILITY OF THESE INSTALLATION ISSUES WITH THE ARCHITECT, STRUCTURAL ENGINEER, GENERAL CONTRACTOR AND/OR BUILDING OWNER.

PANEL BOX BELOW-SOFFIT

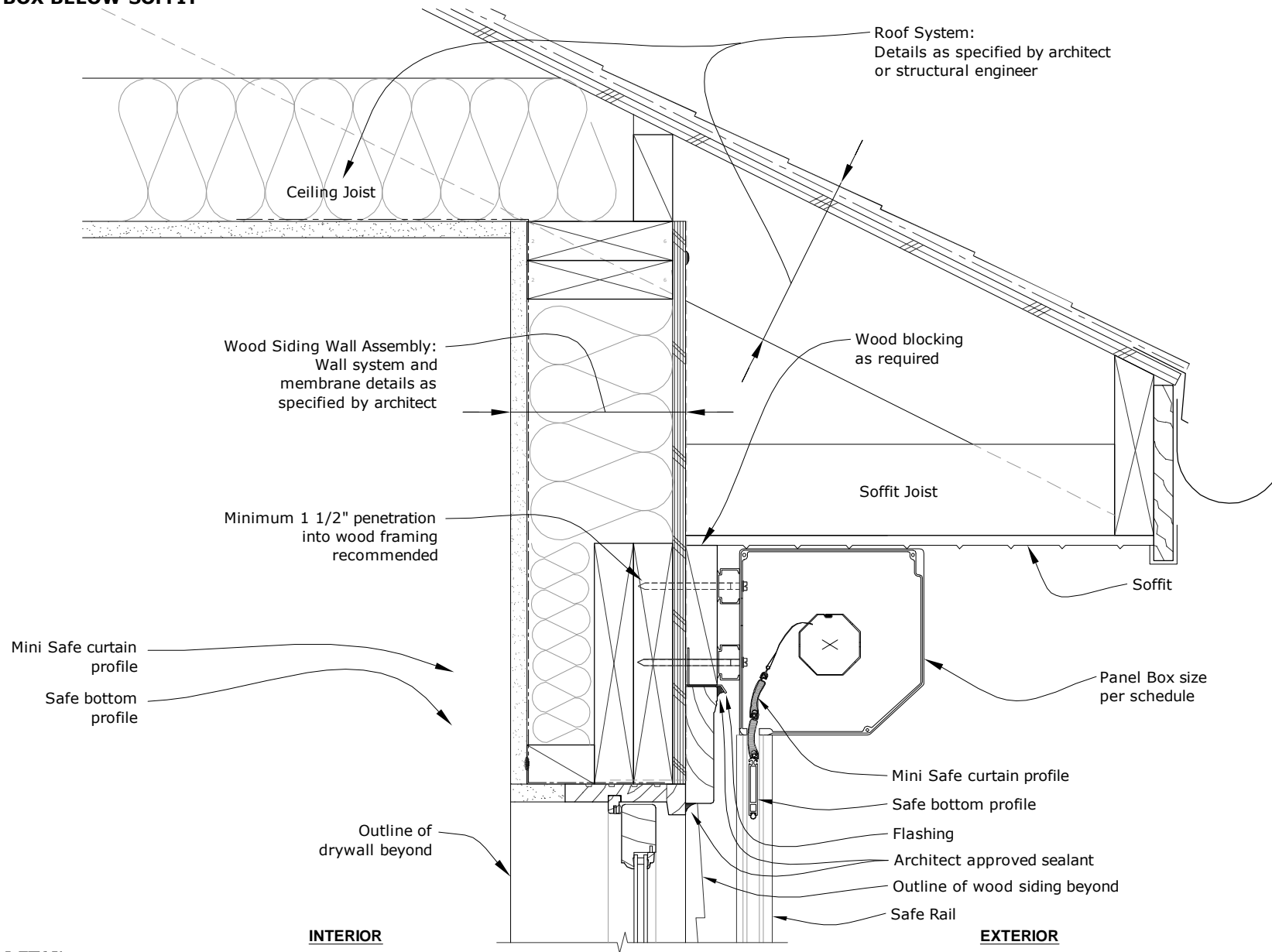

SOFFIT DETAIL

NOTE: IT IS THE SOLE RESPONSIBILITY OF THE GENERAL CONTRACTOR TO SUPPLY ALL REQUIRED SEALANTS, FLASHINGS, AND MOUNTING HARDWARE.

DISCLAIMER: DETAILS PROVIDED BY TALIUS ARE GENERAL RECOMMENDATIONS. CONSULTATION WITH AN EXPERIENCED ARCHITECT, STRUCTURAL ENGINEER, OR CONTRACTOR IS NECESSARY FOR PROPER EXECUTION OF WEATHERPROOFING DETAILS, STRUCTURAL REQUIREMENTS AND COMPLIANCE WITH REGIONAL AND LOCAL BUILDING CODES. TALIUS PLACES SOLE RESPONSIBILITY OF THESE INSTALLATION ISSUES WITH THE ARCHITECT, STRUCTURAL ENGINEER, GENERAL CONTRACTOR AND/OR BUILDING OWNER.

PANEL BOX BELOW-SOFFIT

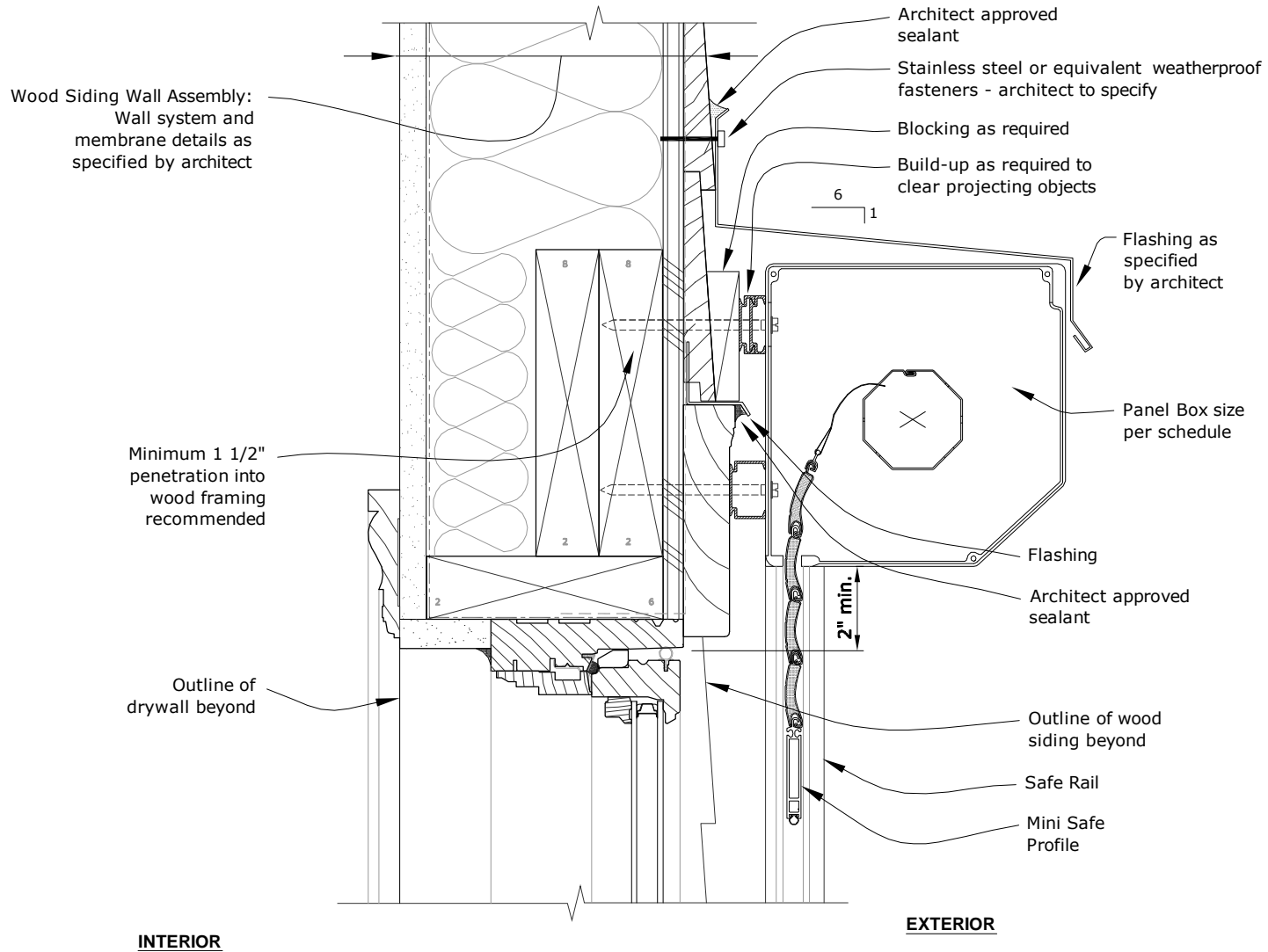

PANEL BOX / WINDOW HEAD DETAIL

NOTE: IT IS THE SOLE RESPONSIBILITY OF THE GENERAL CONTRACTOR TO SUPPLY ALL REQUIRED SEALANTS, FLASHINGS, AND MOUNTING HARDWARE.

DISCLAIMER: DETAILS PROVIDED BY TALIUS ARE GENERAL RECOMMENDATIONS. CONSULTATION WITH AN EXPERIENCED ARCHITECT, STRUCTURAL ENGINEER, OR CONTRACTOR IS NECESSARY FOR PROPER EXECUTION OF WEATHERPROOFING DETAILS, STRUCTURAL REQUIREMENTS AND COMPLIANCE WITH REGIONAL AND LOCAL BUILDING CODES. TALIUS PLACES SOLE RESPONSIBILITY OF THESE INSTALLATION ISSUES WITH THE ARCHITECT, STRUCTURAL ENGINEER, GENERAL CONTRACTOR AND/OR BUILDING OWNER.

PANEL BOX BELOW-SOFFIT

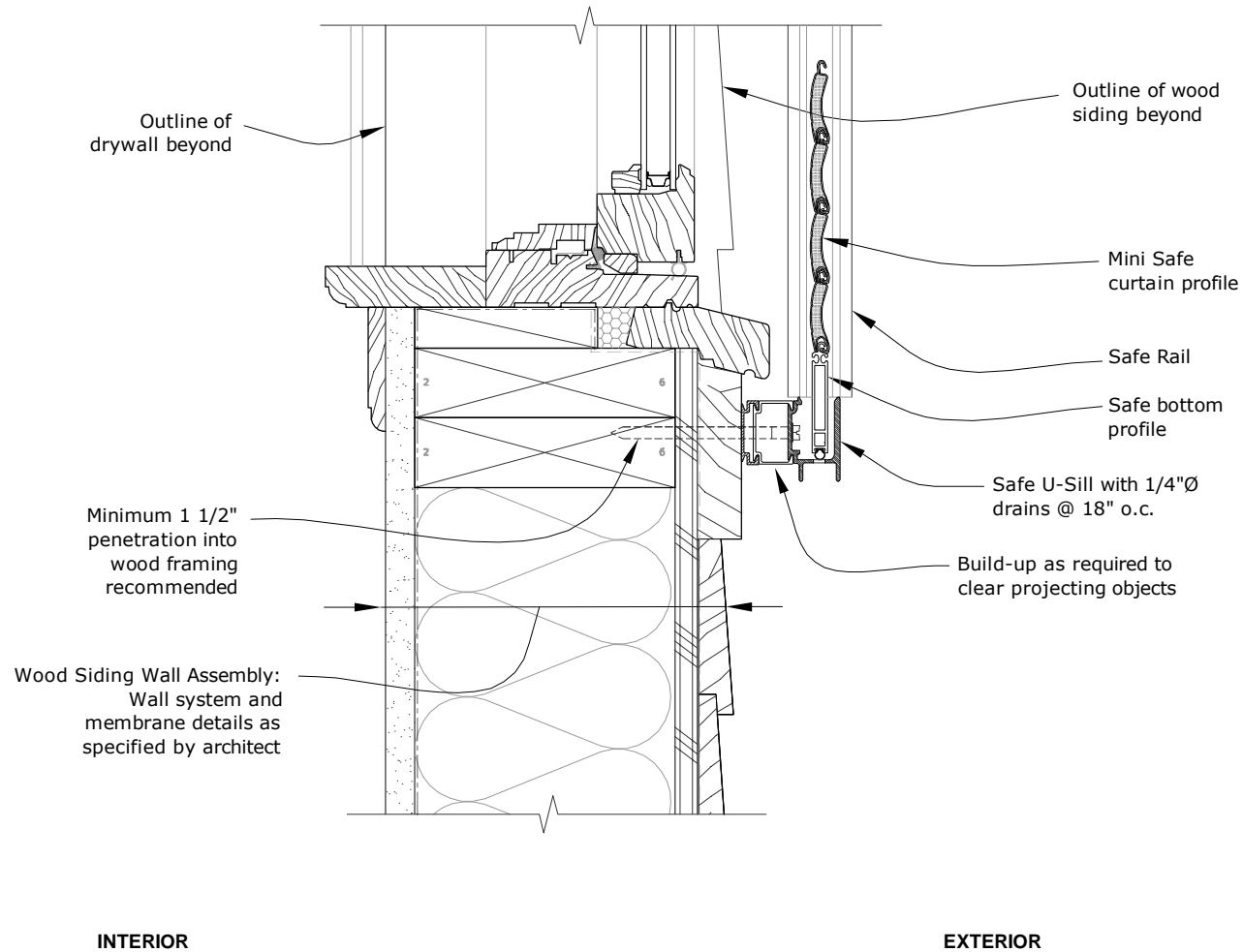

WINDOW SILL DETAIL

NOTE: IT IS THE SOLE RESPONSIBILITY OF THE GENERAL CONTRACTOR TO SUPPLY ALL REQUIRED SEALANTS, FLASHINGS, AND MOUNTING HARDWARE.

DISCLAIMER: DETAILS PROVIDED BY TALIUS ARE GENERAL RECOMMENDATIONS. CONSULTATION WITH AN EXPERIENCED ARCHITECT, STRUCTURAL ENGINEER, OR CONTRACTOR IS NECESSARY FOR PROPER EXECUTION OF WEATHERPROOFING DETAILS, STRUCTURAL REQUIREMENTS AND COMPLIANCE WITH REGIONAL AND LOCAL BUILDING CODES. TALIUS PLACES SOLE RESPONSIBILITY OF THESE INSTALLATION ISSUES WITH THE ARCHITECT, STRUCTURAL ENGINEER, GENERAL CONTRACTOR AND/OR BUILDING OWNER.

PANEL BOX BELOW-SOFFIT

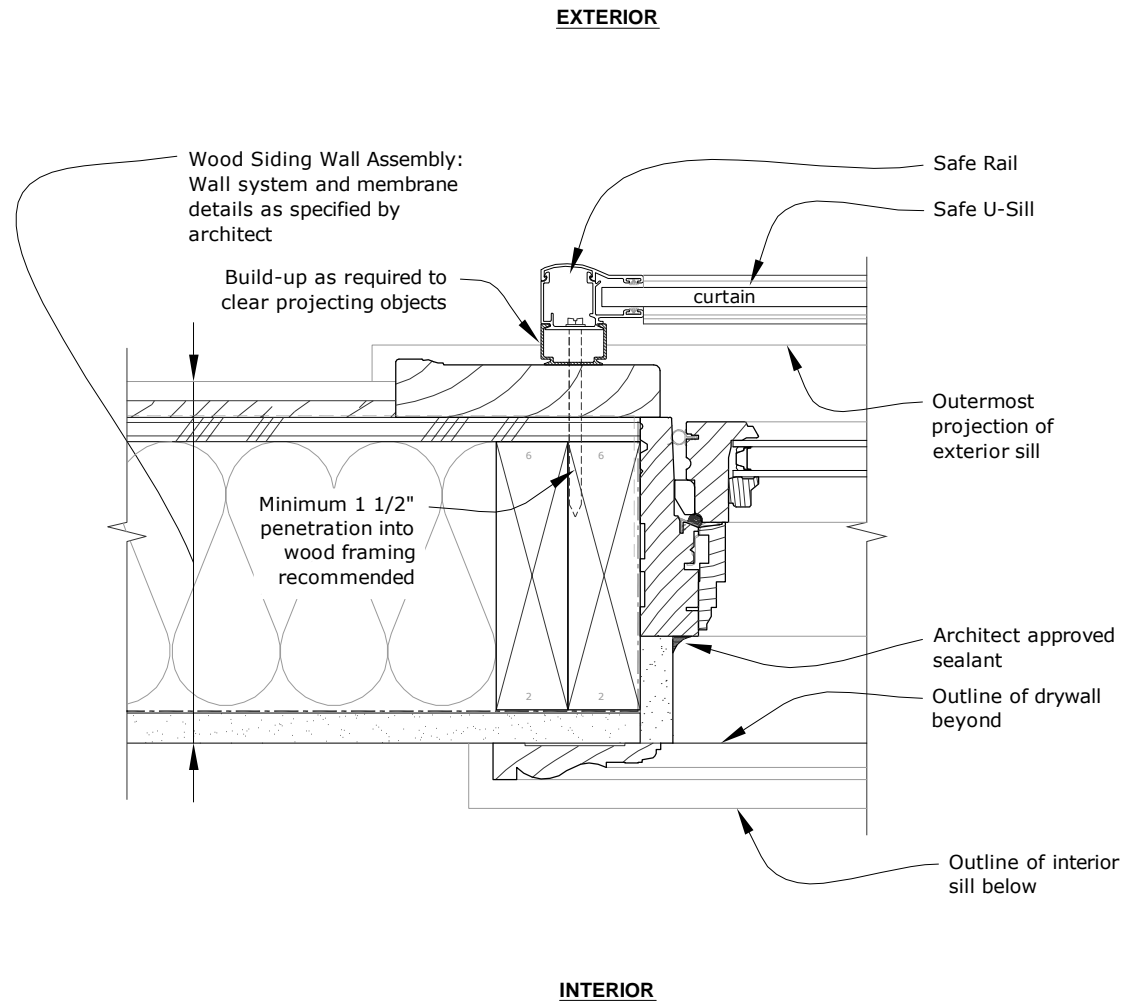

WINDOW JAMB DETAIL

NOTE: IT IS THE SOLE RESPONSIBILITY OF THE GENERAL CONTRACTOR TO SUPPLY ALL REQUIRED SEALANTS, FLASHINGS, AND MOUNTING HARDWARE.

DISCLAIMER: DETAILS PROVIDED BY TALIU ARE GENERAL RECOMMENDATIONS. CONSULTATION WITH AN EXPERIENCED ARCHITECT, STRUCTURAL ENGINEER, OR CONTRACTOR IS NECESSARY FOR PROPER EXECUTION OF WEATHERPROOFING DETAILS, STRUCTURAL REQUIREMENTS AND COMPLIANCE WITH REGIONAL AND LOCAL BUILDING CODES. TALIU PLACES SOLE RESPONSIBILITY OF THESE INSTALLATION ISSUES WITH THE ARCHITECT, STRUCTURAL ENGINEER, GENERAL CONTRACTOR AND/OR BUILDING OWNER.

PANEL BOX BELOW-SOFFIT

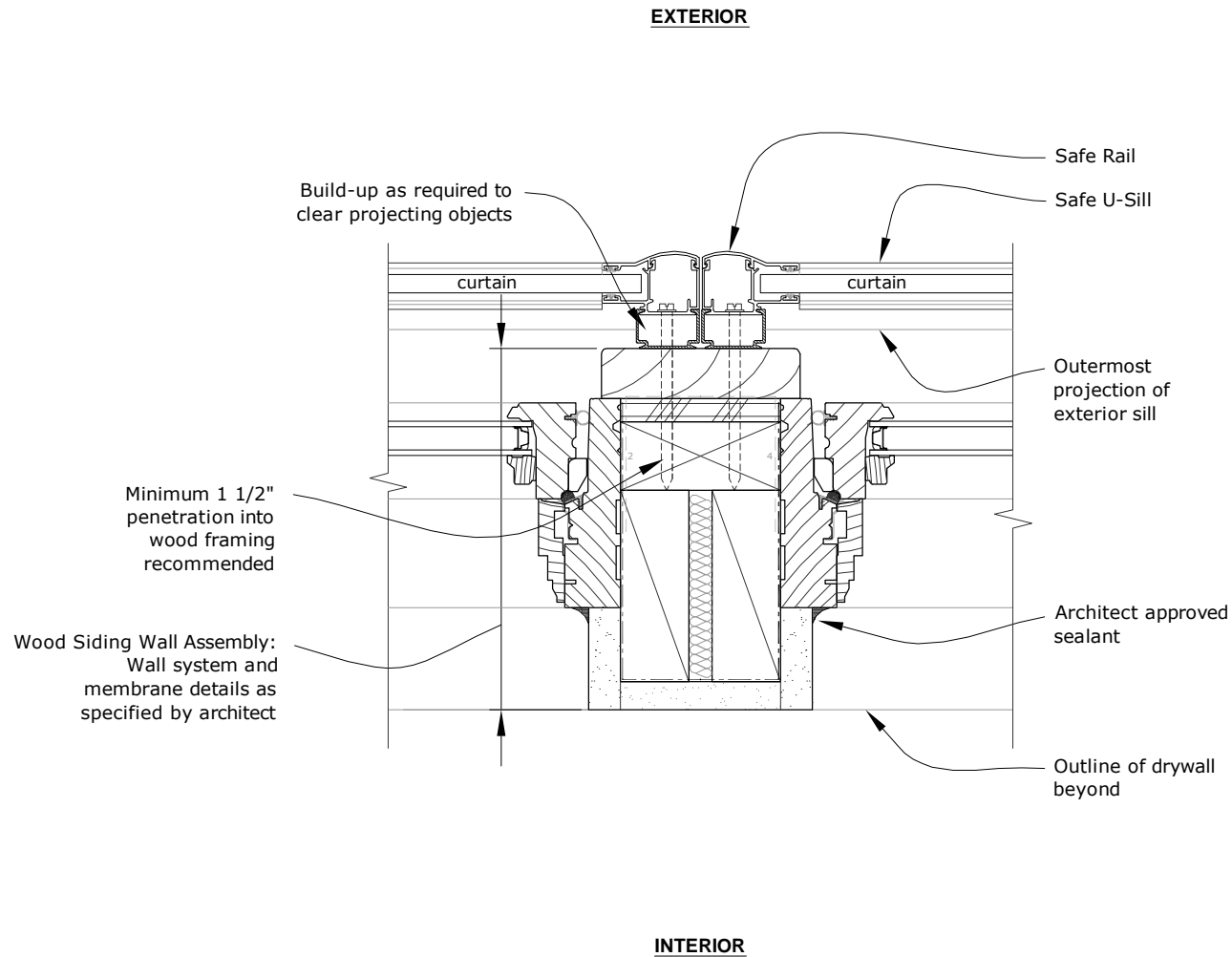

WINDOW JAMB w/ SAFE RAILS BACK-TO-BACK

NOTE: IT IS THE SOLE RESPONSIBILITY OF THE GENERAL CONTRACTOR TO SUPPLY ALL REQUIRED SEALANTS, FLASHINGS, AND MOUNTING HARDWARE.

DISCLAIMER: DETAILS PROVIDED BY TALIUS ARE GENERAL RECOMMENDATIONS. CONSULTATION WITH AN EXPERIENCED ARCHITECT, STRUCTURAL ENGINEER, OR CONTRACTOR IS NECESSARY FOR PROPER EXECUTION OF WEATHERPROOFING DETAILS, STRUCTURAL REQUIREMENTS AND COMPLIANCE WITH REGIONAL AND LOCAL BUILDING CODES. TALIUS PLACES SOLE RESPONSIBILITY OF THESE INSTALLATION ISSUES WITH THE ARCHITECT, STRUCTURAL ENGINEER, GENERAL CONTRACTOR AND/OR BUILDING OWNER.

PANEL BOX IN-WALL SYSTEM

Wall thickness will vary with rollshutter housing size.
Talius housing sizes must be coordinated with actual lumber sizes to avoid conflicts - to be specified by architect or structural engineer

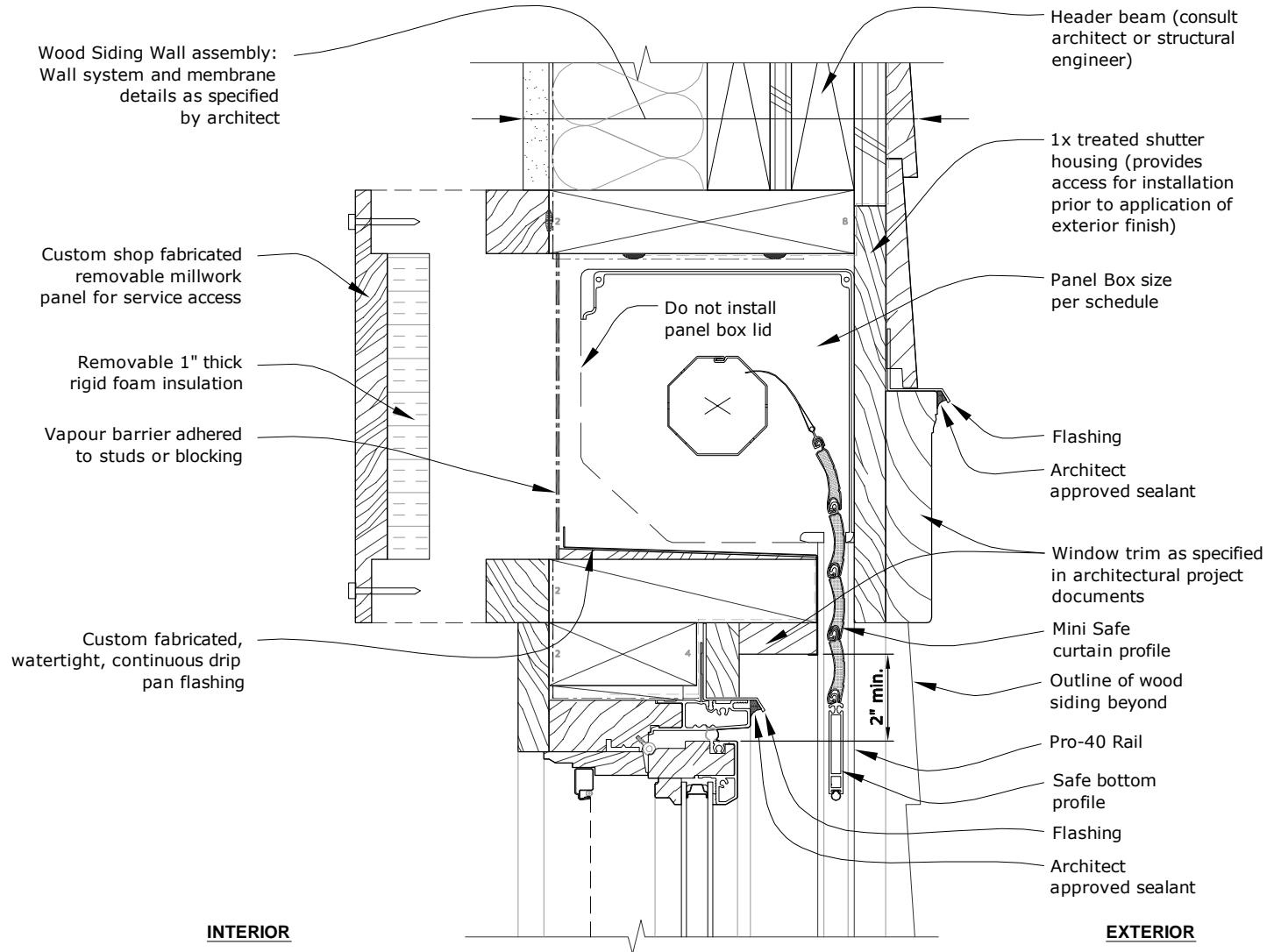

PANEL BOX / WINDOW HEAD DETAIL

NOTE: IT IS THE SOLE RESPONSIBILITY OF THE GENERAL CONTRACTOR TO SUPPLY ALL REQUIRED SEALANTS, FLASHINGS, AND MOUNTING HARDWARE.

DISCLAIMER: DETAILS PROVIDED BY TALIUS ARE GENERAL RECOMMENDATIONS. CONSULTATION WITH AN EXPERIENCED ARCHITECT, STRUCTURAL ENGINEER, OR CONTRACTOR IS NECESSARY FOR PROPER EXECUTION OF WEATHERPROOFING DETAILS, STRUCTURAL REQUIREMENTS AND COMPLIANCE WITH REGIONAL AND LOCAL BUILDING CODES. TALIUS PLACES SOLE RESPONSIBILITY OF THESE INSTALLATION ISSUES WITH THE ARCHITECT, STRUCTURAL ENGINEER, GENERAL CONTRACTOR AND/OR BUILDING OWNER.

PANEL BOX IN-WALL SYSTEM

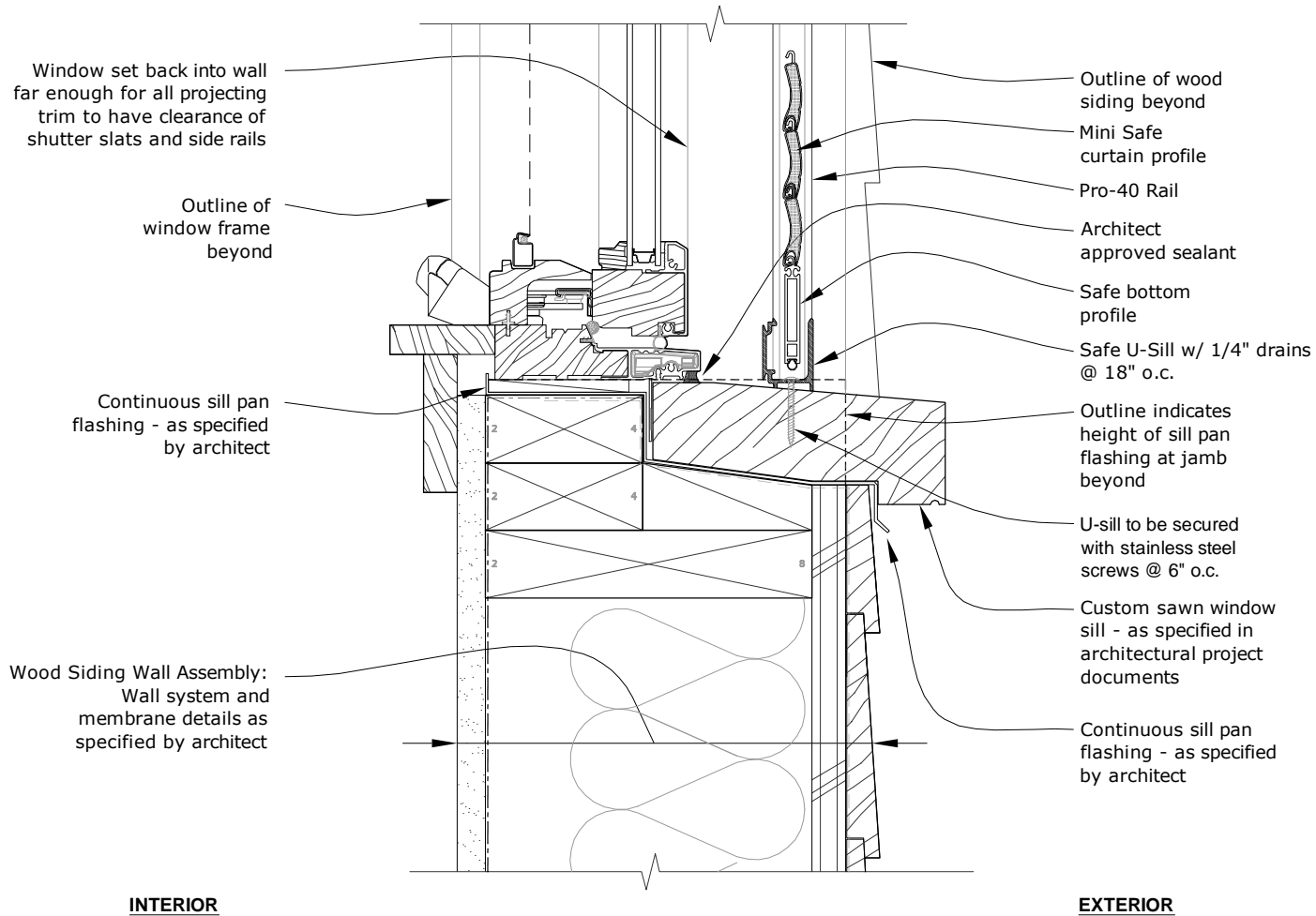

WINDOW SILL DETAIL

NOTE: IT IS THE SOLE RESPONSIBILITY OF THE GENERAL CONTRACTOR TO SUPPLY ALL REQUIRED SEALANTS, FLASHINGS, AND MOUNTING HARDWARE.

DISCLAIMER: DETAILS PROVIDED BY TALIUS ARE GENERAL RECOMMENDATIONS. CONSULTATION WITH AN EXPERIENCED ARCHITECT, STRUCTURAL ENGINEER, OR CONTRACTOR IS NECESSARY FOR PROPER EXECUTION OF WEATHERPROOFING DETAILS, STRUCTURAL REQUIREMENTS AND COMPLIANCE WITH REGIONAL AND LOCAL BUILDING CODES. TALIUS PLACES SOLE RESPONSIBILITY OF THESE INSTALLATION ISSUES WITH THE ARCHITECT, STRUCTURAL ENGINEER, GENERAL CONTRACTOR AND/OR BUILDING OWNER.

PANEL BOX IN-WALL SYSTEM

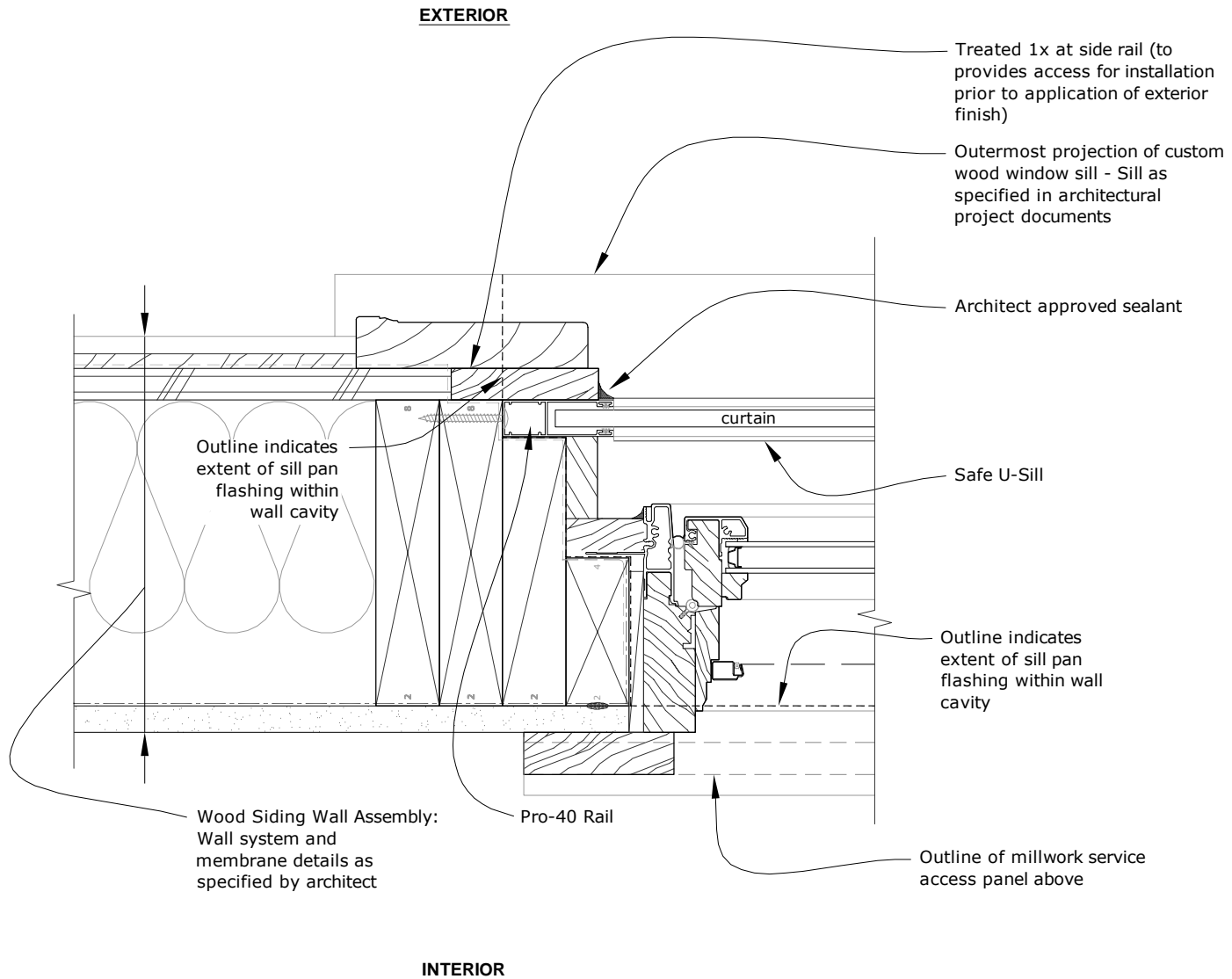

WINDOW JAMB DETAIL

NOTE: IT IS THE SOLE RESPONSIBILITY OF THE GENERAL CONTRACTOR TO SUPPLY ALL REQUIRED SEALANTS, FLASHINGS, AND MOUNTING HARDWARE.

DISCLAIMER: DETAILS PROVIDED BY TALIUS ARE GENERAL RECOMMENDATIONS. CONSULTATION WITH AN EXPERIENCED ARCHITECT, STRUCTURAL ENGINEER, OR CONTRACTOR IS NECESSARY FOR PROPER EXECUTION OF WEATHERPROOFING DETAILS, STRUCTURAL REQUIREMENTS AND COMPLIANCE WITH REGIONAL AND LOCAL BUILDING CODES. TALIUS PLACES SOLE RESPONSIBILITY OF THESE INSTALLATION ISSUES WITH THE ARCHITECT, STRUCTURAL ENGINEER, GENERAL CONTRACTOR AND/OR BUILDING OWNER.

PANEL BOX IN-WALL SYSTEM

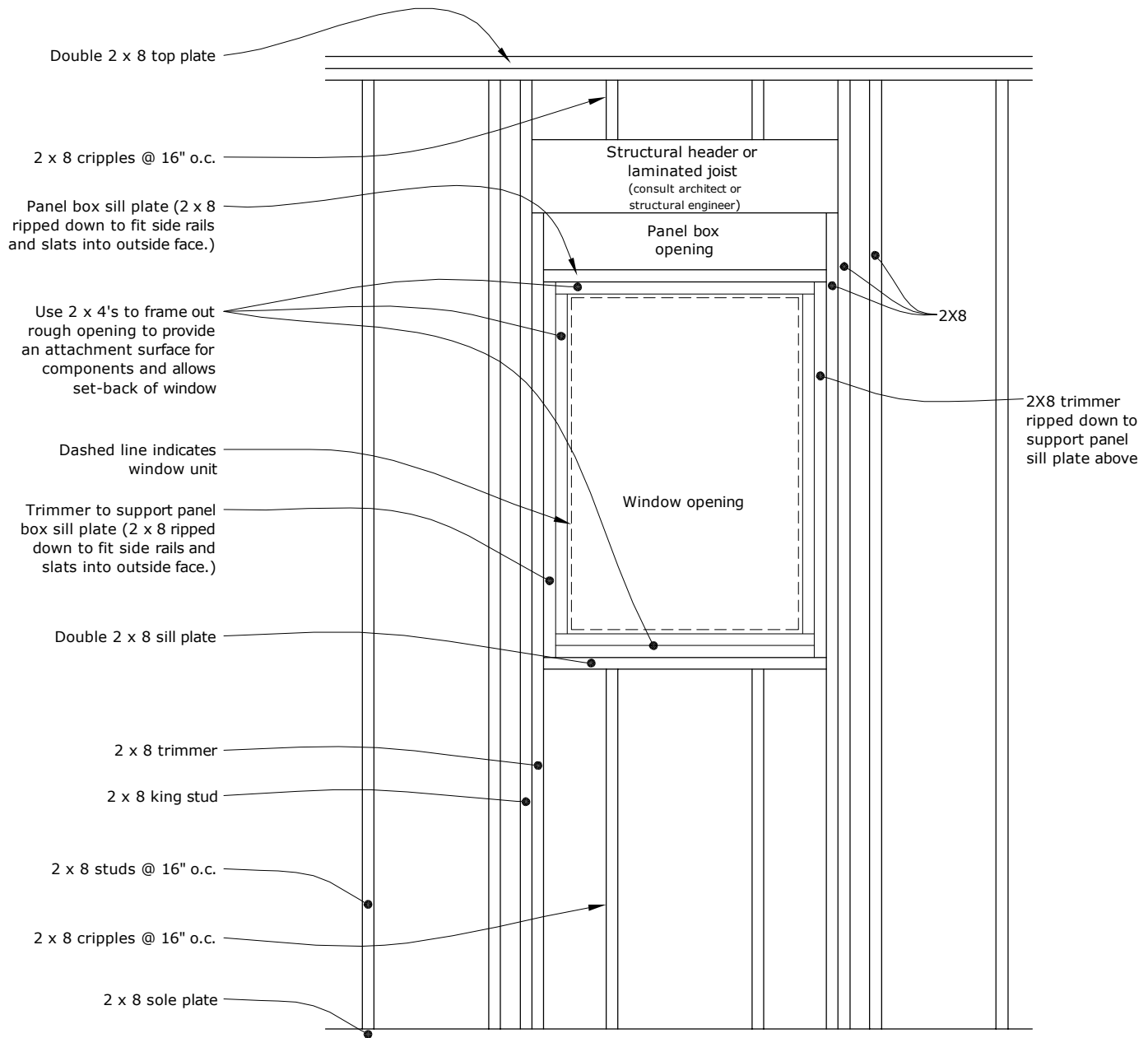

FRAMING DIAGRAM

NOTE: IT IS THE SOLE RESPONSIBILITY OF THE GENERAL CONTRACTOR TO SUPPLY ALL REQUIRED SEALANTS, FLASHINGS, AND MOUNTING HARDWARE.

DISCLAIMER: DETAILS PROVIDED BY TALIUS ARE GENERAL RECOMMENDATIONS. CONSULTATION WITH AN EXPERIENCED ARCHITECT, STRUCTURAL ENGINEER, OR CONTRACTOR IS NECESSARY FOR PROPER EXECUTION OF WEATHERPROOFING DETAILS, STRUCTURAL REQUIREMENTS AND COMPLIANCE WITH REGIONAL AND LOCAL BUILDING CODES. TALIUS PLACES SOLE RESPONSIBILITY OF THESE INSTALLATION ISSUES WITH THE ARCHITECT, STRUCTURAL ENGINEER, GENERAL CONTRACTOR AND/OR BUILDING OWNER.